

HATCH

Edwin I. Hatch Nuclear Plant





Edwin I. Hatch Nuclear Plant



About Plant Hatch

Situated on the Appling County banks of the Altamaha, Georgia's largest river, the Edwin I. Hatch Nuclear Plant has the capacity to produce up to 1,848,000 kilowatts of electric power. From this region of Spanish moss and white-tailed deer, Plant Hatch's electricity courses along miles and miles of transmission lines to distribution points — homes, factories, businesses and schools — all across the state.

As Georgia's first nuclear-powered electric generating station, Plant Hatch has supplied an average of more than 8 percent of Georgia's total electricity needs since it began operating in 1975. Managed and operated by Southern Nuclear Operating Company, the plant is owned by Georgia Power, Oglethorpe Power Corporation (power supplier to 38 of Georgia's 42 consumer-owned electric membership corporations), the Municipal Electric Authority of Georgia (comprising 49 member participants) and Dalton Utilities. These co-owners of Plant Hatch provide electricity to more than 2 million Georgians in all but four of Georgia's 159 counties.

Construction of the plant began in 1968. Unit 1 began commercial operation in December 1975 and Unit 2 began commercial operation in September 1979. In January 2002, the Nuclear Regulatory Commission (NRC) issued new, extended operating licenses for the Plant Hatch units. This enables Units 1 and 2 to operate an additional 20 years until 2034 and 2038, respectively. Plant Hatch was the first Boiling Water Reactor (BWR) in the U.S. to receive approval for new, extended licenses.

Plant Hatch sits on a 2,244-acre tract that accommodates two reactor units in massive containment buildings and eight cooling towers, a turbine room the size of two football fields, a state-of-the-art control room, an environmental lab, a high-voltage switch yard and substation, and a visitors center that is open to the public all year for scheduled tours. More than 800 people – including engineers, mechanics, reactor operators, lab technicians, instrument and control technicians, electricians and security officers – oversee the plant's operations and maintain its system and facilities.

As people move to the southeastern United States and use greater amounts of electricity, additional power plants using nuclear energy, such as Plant Hatch, are needed.

How Nuclear Power Plants Operate

Most power plants generate electricity by heating water to produce steam. This steam fans the propeller-like blades of a turbine connected to the generator shaft. The electrical current from the generator is then fed to a network of wires (the electric grid) and delivered to consumers.

While fossil power plants generate steam by burning oil, gas or coal, nuclear power plants generate steam with the use of tons of ceramic pellets made from uranium or other fissionable elements. The cylindrical pellets, each about the size of the end of your little finger, are arranged in long vertical tubes within the reactor. These tubes, known as fuel rods in the reactor core, contain uranium oxide pellets. In a neutron chain reaction inside the reactor vessel, the uranium atoms fission, or split, creating heat. When water is pumped from the bottom of the reactor up around the hot fuel rods, it is vaporized into steam. The steam turns the turbine generator, just as in any other steam-based electric generating plant.

Inserted throughout the bundles of fuel rods are many “control rods.” Operation of the reactor is controlled by varying the number of control rods and the

This simplified diagram shows how the steam generating process works.

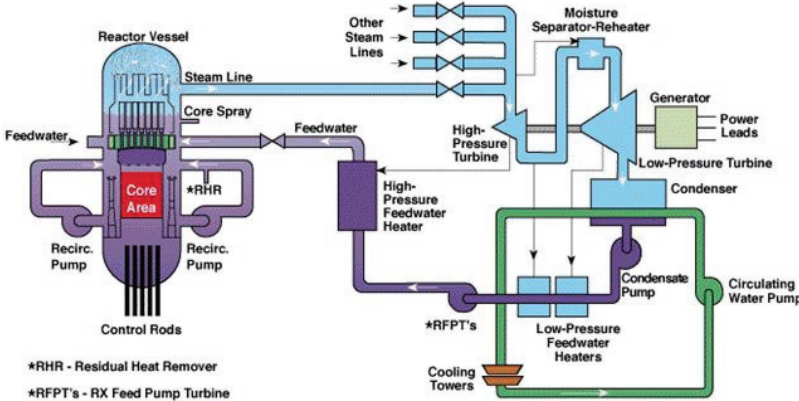



Plant Hatch's Unit 1 Generator

degree to which they are inserted or withdrawn and by controlling other plant parameters.

After the steam turns the turbine, it is funneled into a condenser to be cooled into liquid again and sent back through the reactor to make more steam. This way, in a closed cycle, the same water is used over and over again.

At Plant Hatch, a separate, non-radioactive loop of water drawn from the Altamaha River serves as the coolant in the condenser. After its trip through the condenser, this “cooling water” is pumped through the plant’s huge cooling towers until it cools off enough to be run through the condenser again.

Public Safety

Safety is the top priority of the U.S. nuclear energy industry. We take very seriously our obligation to protect the health and safety of our employees, the public and the environment.

Securing Our Facilities

Prior to Sept. 11, 2001, nuclear power plants were the most secure facilities of any industrial sites in the nation. Since Sept. 11, the nuclear power industry has taken a number of significant steps to reinforce and enhance our security measures, including increased personnel, training, technology and barriers

– spending an additional \$1.2 billion on security throughout all commercial nuclear power facilities in the United States.

Nuclear power plants are an important component of the nation’s critical infrastructure and have been designed with multiple layers of protection, including structural strength, highly trained operators and proven emergency plans.

The NRC holds nuclear power plants to the highest security standards of any American industry. And of the 17 infrastructure categories currently under evaluation by the U.S. Department of Homeland Security, the agency has said the nuclear reactor sector is by far the best protected. Furthermore, the nuclear reactor sector is used by Homeland Security as its security standard.

Emergency Planning

Comprehensive plans have been developed in accordance with federal requirements by the NRC and other oversight agencies to respond to an emergency at any of the Southern Nuclear operated facilities. Southern Nuclear has overall responsibility for the emergency plan, which involves Southern Nuclear, Georgia Power, and the various county, state and federal agencies.

The emergency plan specifies the procedures, personnel and equipment, which would be used to classify an emergency, to define and assign responsibilities and to outline an effective course of action for safeguarding personnel, property and the general public.

These plans are updated regularly and maintained at all times. Drills and exercises are conducted annually to test these plans and to train and test personnel on following procedures correctly.

Should an emergency occur, one of the first steps would be to notify off-site authorities such as the Georgia Emergency Management Agency, NRC and local county officials. Communication would be maintained with these agencies to keep them fully aware of the emergency status, including on-site and off-site radiological information.

Radiation

The combined effect of the structural, mechanical and human safety systems built into our nuclear plants means that a person living within a few miles of its reactors receives less radiation from its presence than from watching a color television.

Radiation to the human body is measured in millirem; the average “background” radiation from our natural environment (sunlight, food, rocks, soil) adds up to around 250 to 300 millirem a year, depending on where we live. Other man-made sources of low-level radiation add greatly to this total.

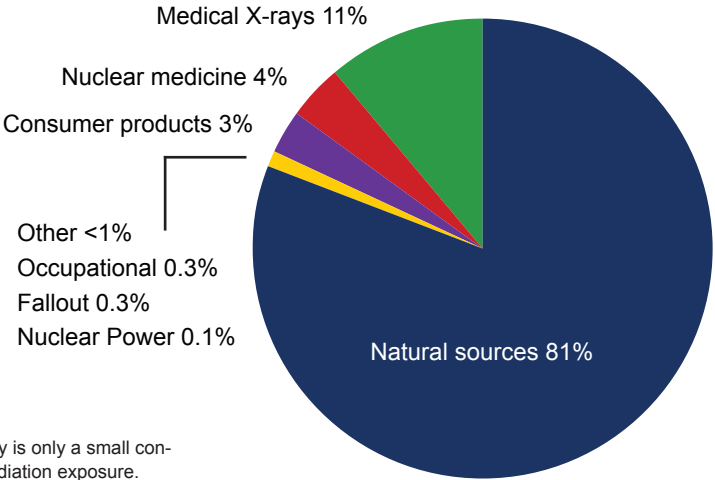

The nuclear power industry is only a small contributor to your average radiation exposure.

A typical chest X-ray is about 10 millirem of radiation; a jet airplane flight from New York to California and back again adds five millirem. Living within a five-mile radius of a nuclear power plant will give less than one millirem of radiation exposure per year to an individual. The average person will receive less than one millirem of radiation exposure per year from watching color television.

Federal regulatory agencies carefully set and enforce dose limits to protect the public, the environment and plant employees.

Defense in Depth

Nuclear power plants are designed with many redundant safety systems, sometimes called “defense in depth.” Fuel pellets, which are about 4.2 percent fissionable U-235, are sealed in zircaloy tubes. The fuel assemblies are then contained in a reactor vessel, which has six inch-thick steel walls and weighs 505 tons. The vessel is contained in a “drywell” fabricated of 1.5 inches of steel. The drywell is surrounded by five feet of reinforced concrete. All of this is housed in a reactor building. There are several redundant cooling systems that minimize the possibility of overheating the reactor core. A nuclear reactor, such as Plant Hatch, operating at full power can be shut down in a few seconds by rapidly inserting the control rods to stop the fission process.

New Nuclear Plant Development

Southern Company currently is exploring various opportunities to build new nuclear-powered electric generating plants to serve our customers’ energy needs for the future. Southern Company’s actions are part of our long-range generation-planning process that seeks to identify the most cost-effective, reliable and environmentally responsible fuel sources to meet growing electricity demand in the areas we serve. Nuclear power is a proven technology that is a viable generating source.

This artist rendering depicts the two new units (Westinghouse AP1000s) at Plant Vogtle.



Increased demand for energy is driving the need for new baseload capacity. The population of the southeastern United States continues to expand rapidly, and according to the U.S. Department of Energy, 40 percent of the U.S. population will live in the Southeast by 2030. The state of Georgia alone is expected to grow by 4 million people by 2030. During the next 15 years, electrical demand on the Georgia Power system is projected to grow 30 percent.

As energy needs grow in the Southeast, Southern Company intends to be on the forefront of exploring nuclear energy as an option for meeting rising electricity demand. The process to build two new reactors at Plant Vogtle is well underway, with plans to begin commercial operation of Unit 3 in 2016 and Unit 4 in 2017.

Nuclear power is a safe, reliable, cost-effective power source that has a low impact on the environment. It is a prudent business decision to use nuclear energy as a means to meet our customers' needs.

The Nuclear Advantage

Nuclear energy is a safe, reliable, cost-effective form of energy. Southern Company has operated nuclear plants safely and reliably for more than 25 years, and all three of our plants have operated at high levels of reliability. The average three-year capacity factor of our nuclear power plants is 92.48 percent. Capacity factor is the percent of time the unit is available to provide power to the electrical grid. Nuclear power has a low production cost compared with other fuel sources. Uranium is used as nuclear fuel, and it has less price volatility than other fuel sources.

Nuclear power adds diversity to our fuel mix. Twenty percent of the nation's electricity is supplied by nuclear power, and behind coal, it is the second leading source of electricity. The use of nuclear power increases our independence by decreasing our dependence on foreign oil.

Nuclear power produces no greenhouse gases, making it a sound, environmentally responsible fuel source. Nuclear power accounts for three-quarters of all emission-free electric generating capacity in this country.

Nuclear power will continue to play an important role in meeting the growing energy needs of Southern Company customers, as the Southeastern U.S. continues to expand rapidly.

Protecting Our Environment

Plant Hatch's Commitment to the Environment

Plant Hatch is committed to the protection of the environment and the enhancement of wildlife. In 1987, a formal land management plan was developed for the plant. This plan focused on management of timber on the approximately 1414 acres of forested land, but also contained considerations for management of wildlife in timber areas and protection of wetland areas to enhance wildlife habitat. Since 1994, Plant Hatch has been recognized as a certified member of the Wild Life Habitat Council. The council is a non-profit international organization dedicated to protecting and



A variety of wildlife, such as these geese, often can be spotted on Plant Hatch grounds. The plant is a certified member of the Wildlife Habitat Council.

enhancing wildlife habitat. Plant Hatch management programs include timber management activities, prescribed burning, selective mowing, planting of food plots for deer and turkey and management of habitat for songbirds, raptors, bats and fox squirrels. Through the wildlife management program the plant maintains nesting boxes for barred owls, wood ducks, kestrel hawks, and a

nesting platform for osprey. Plant Hatch employees also participate in the bluebird nest monitoring programs from March to September of each year.

Climate Change

Climate change is a challenging issue for our world and our nation. Southern Company is committed to a leadership role in finding solutions that make technological, environmental and economic sense. The focus of this effort must be on developing and deploying technologies that reduce greenhouse gases while ensuring that electricity remains reliable and affordable.

Southern Company is increasing its investment in programs and services that can help customers save money by using electricity more efficiently. These efforts also have the benefit of reducing greenhouse gases by lessening the need to build new generation. The company also is involved in numerous significant research and development projects into advanced coal generation technologies as well as renewable energy. Notable projects include a major demonstration of carbon capture and sequestration technology at an existing coal-based plant in Alabama and the conversion of a coal-fired unit in Georgia to 100 percent wood biomass. As part of our efforts to limit emission of greenhouse gas, Southern Company is considering building new nuclear units as nuclear plants do not emit carbon dioxide — a major greenhouse gas.

Storage of Used Fuel

Under the Nuclear Waste Policy Act of 1982, the U.S. Department of Energy (DOE) is the federal agency responsible for the disposal of high-level waste such as used nuclear fuel. After more than 20 years of exhaustive scientific and engineering research, President George W. Bush and Congress in 2002 approved Yucca Mountain, Nev., as the site of a national repository for used nuclear fuel.

Disposing of used fuel at this remote desert site supports sound national energy, environmental and security policies.

In 2009, the Obama administration announced plans to terminate the Yucca Mountain program and will empanel a blue-ribbon commission of experts

to study alternatives. However, the NRC's Yucca Mountain repository license application review process will continue.

A solid material, used nuclear fuel is safely stored at nuclear power plant sites, either in steel-lined, concrete pools filled with water or in steel or steel-reinforced concrete containers with steel inner canisters. The first on-site storage method is referred to as the spent fuel pool. The second is called dry storage.

Spent Fuel Pool

When most of the U-235 has been used in the fission process, the fuel assemblies are removed and replaced with new fuel assemblies. At most plants, used fuel is stored in large, steel-lined, concrete pools filled with water. These pools are known as spent fuel pools.

Both water and concrete are excellent radiation shields. In these spent fuel pools, the water acts as an absorber and prevents radiation from escaping from the pool. The water also keeps the fuel cool while the fuel decays or becomes less radioactive over time. The water itself never leaves the inside of the plant's concrete auxiliary building.

Dry Storage

The government's delay in providing a permanent repository for used nuclear fuel means that nuclear plants must store more used fuel than expected and store it for longer than originally intended. Since 1986, dozens of U.S. nuclear plants have supplemented their storage capacity by building above-ground dry storage facilities. Other countries also have safely and successfully stored used fuel above ground since the mid-1970s.

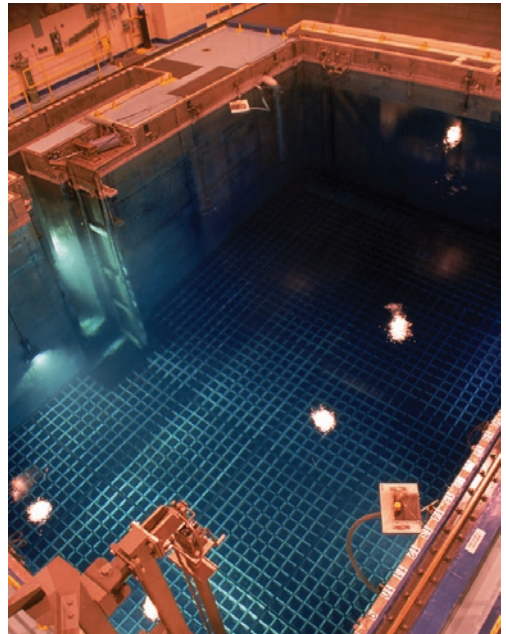

Spent fuel pools are used as one of the safety measures in Southern Company's nuclear plants.

Southern Nuclear uses dry storage at Plants Farley and Hatch. We estimate that dry storage will be needed at Plant Vogtle by 2014.

Dry storage containers are cylindrical containers constructed of steel or steel-reinforced concrete and lead, which serve as proven, effective radiation shields. These containers effectively shield the radiation as used fuel continues its cooling process. Once loaded with used fuel assemblies, the containers are stored horizontally in a concrete vault, or they stand upright on a thick concrete pad.



Dry storage at Plant Hatch.

Each dry storage container design must be approved by the NRC. The agency requires that dry storage containers be constantly monitored. The initial license to use dry storage containers is issued by the NRC, and every 20 years this license must be renewed. The containers are designed and tested to prevent the release of radiation under the most extreme conditions – earthquakes, tornados, hurricanes, floods and sabotage – and they are naturally cooled and ventilated.

Nuclear plants were designed to store at least a decade's worth of used fuel. And, with dry storage, used fuel can be safely stored for much longer. The NRC has determined that used fuel can be safely stored at plant sites for at least 30 years beyond the licensed operating life of the plant. While used nuclear fuel can be safely stored on-site, Southern Company and the industry maintain that a permanent underground repository is the best, long-term solution.

These storage areas are well protected by a combination of sturdy plant construction, state-of-the-art surveillance and detection equipment, and armed, well-trained paramilitary security forces.

Owners and Operators

Southern Nuclear Operating Company, headquartered in Birmingham, Ala., operates Southern Company's six nuclear units at three locations: the Edwin I. Hatch Nuclear Plant, the Joseph M. Farley Nuclear Plant near Dothan, Ala. and the Alvin W. Vogtle Electric Generating Plant near Waynesboro, Ga. Plant Farley was built and is owned by Alabama Power, and the plant generates approximately 19 percent of Alabama Power's electricity. Plant Vogtle and Plant Hatch were built by and are co-owned by Georgia Power Company, Oglethorpe Power Corporation, the Municipal Electric Authority of Georgia, and Dalton Utilities. Together, these two nuclear power plants generate approximately 20 percent of Georgia Power's electricity.

Southern Nuclear, Alabama Power and Georgia Power each are wholly owned subsidiaries of Southern Company. With 4.3 million customers and more than 42,000 megawatts of generating capacity, Atlanta-based Southern Company is the premier energy company serving the Southeast, one of America's fastest-growing regions. A leading U.S. producer of electricity, Southern Company owns electric utilities in four states and a growing competitive generation company, as well as fiber optics and wireless communications.

Southern Company brands are known for excellent customer service, high reliability and retail electric prices that are significantly below the national average. Southern Company has received the highest ranking in customer satisfaction among U.S. electric service providers for seven consecutive years by the American Customer Satisfaction Index (ACSI). You can access our website by logging on to **www.southerncompany.com**.

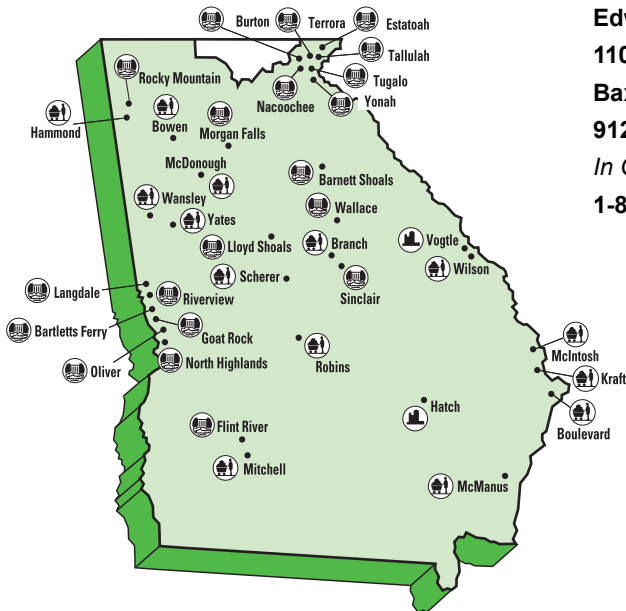

LEGEND

-  FOSSIL
-  NUCLEAR
-  HYDRO

Edwin I. Hatch Visitors Center
11036 Hatch Parkway N.
Baxley, GA 31513
912-366-2204
In Georgia call:
1-800-722-7774



© Southern Nuclear